

Instruction Manual

**G-800S/G-1000S
G-800SDX/G-1000SDX**

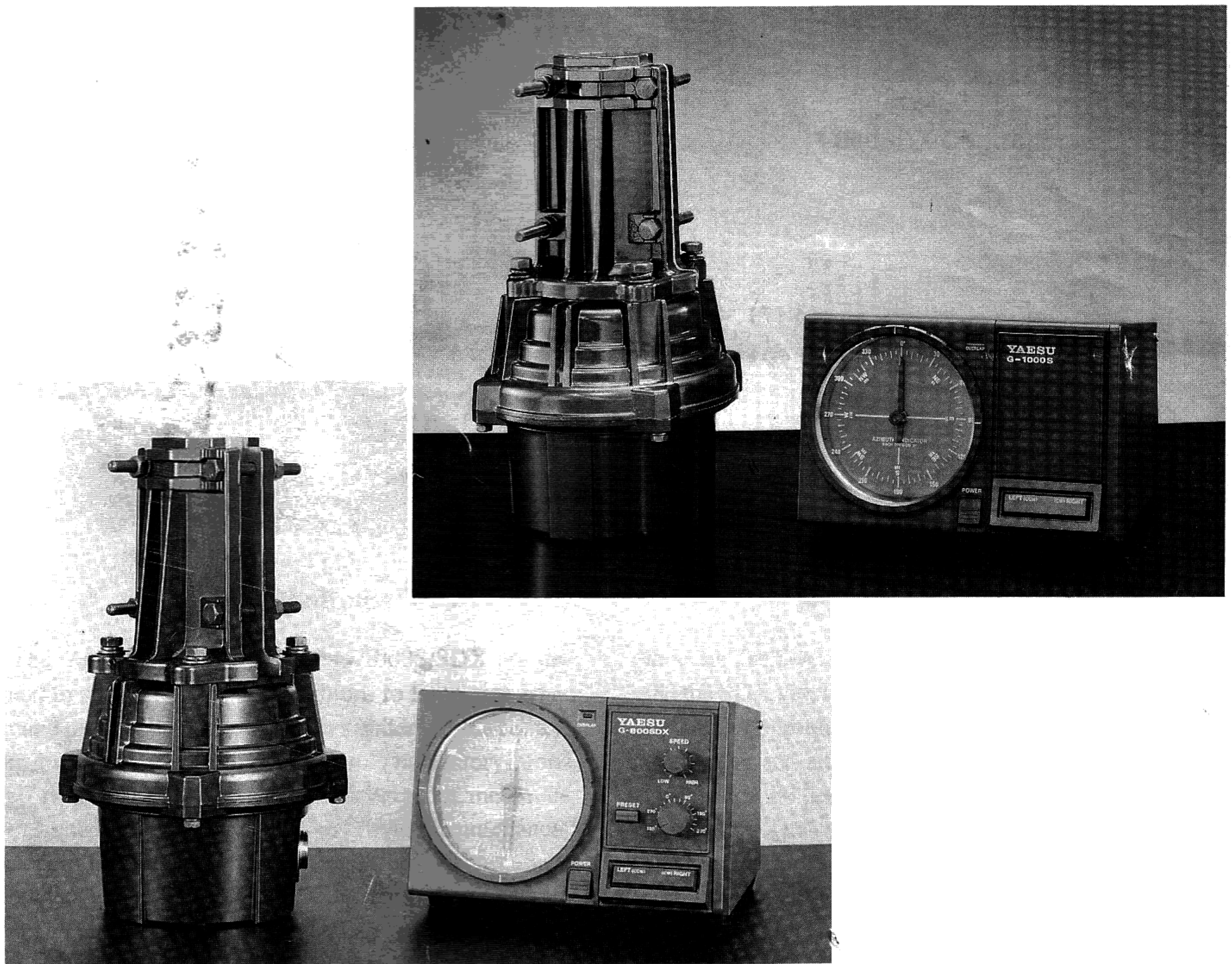

**Yaesu Musen Co., Ltd.
C. P. O. Box 1500
Tokyo, Japan**

YAESU G-800S/SDX & G-1000S/SDX Heavy-Duty Antenna Rotator & Controllers



G-800S Controller

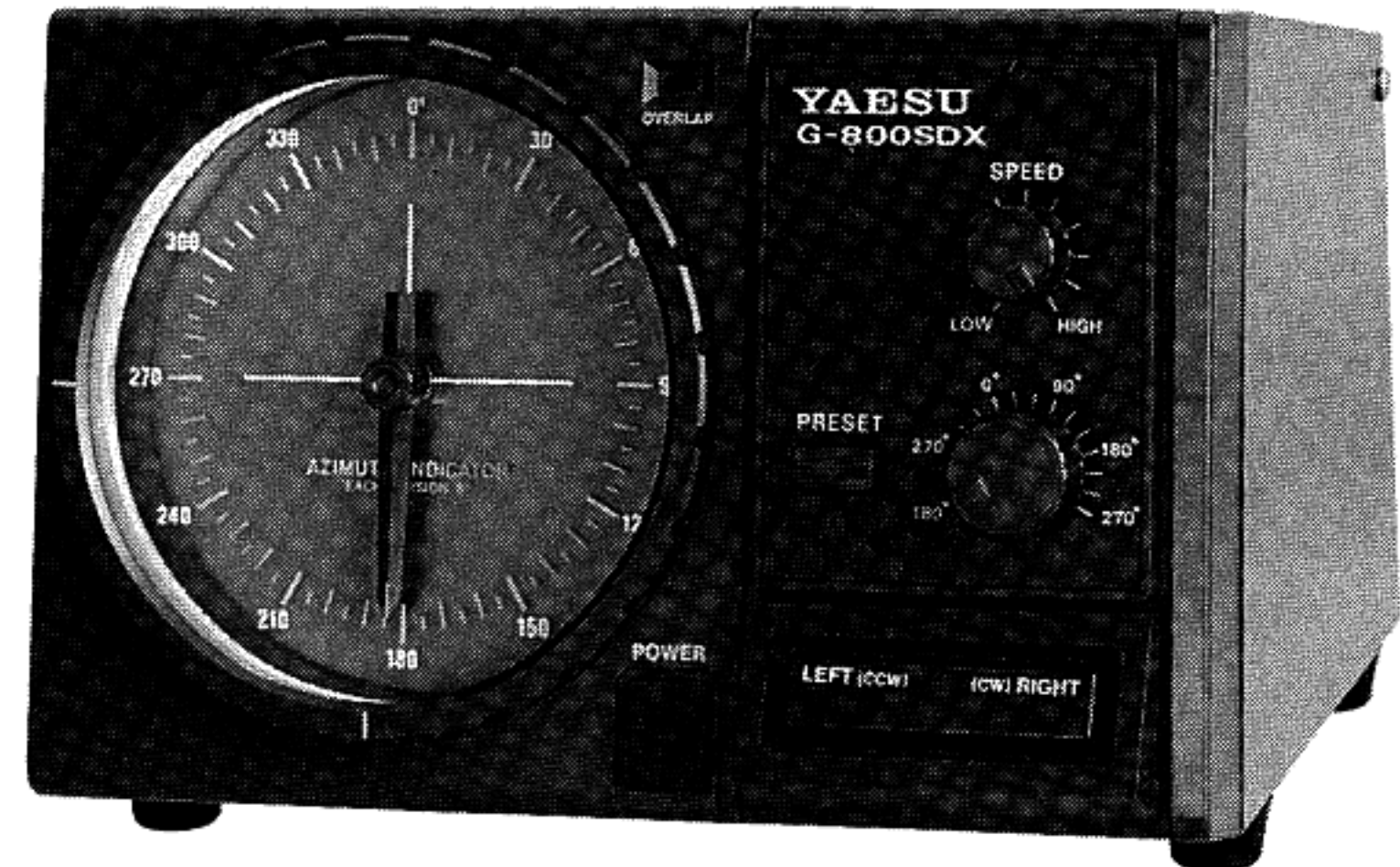

G-800SDX Controller



G-1000S Controller

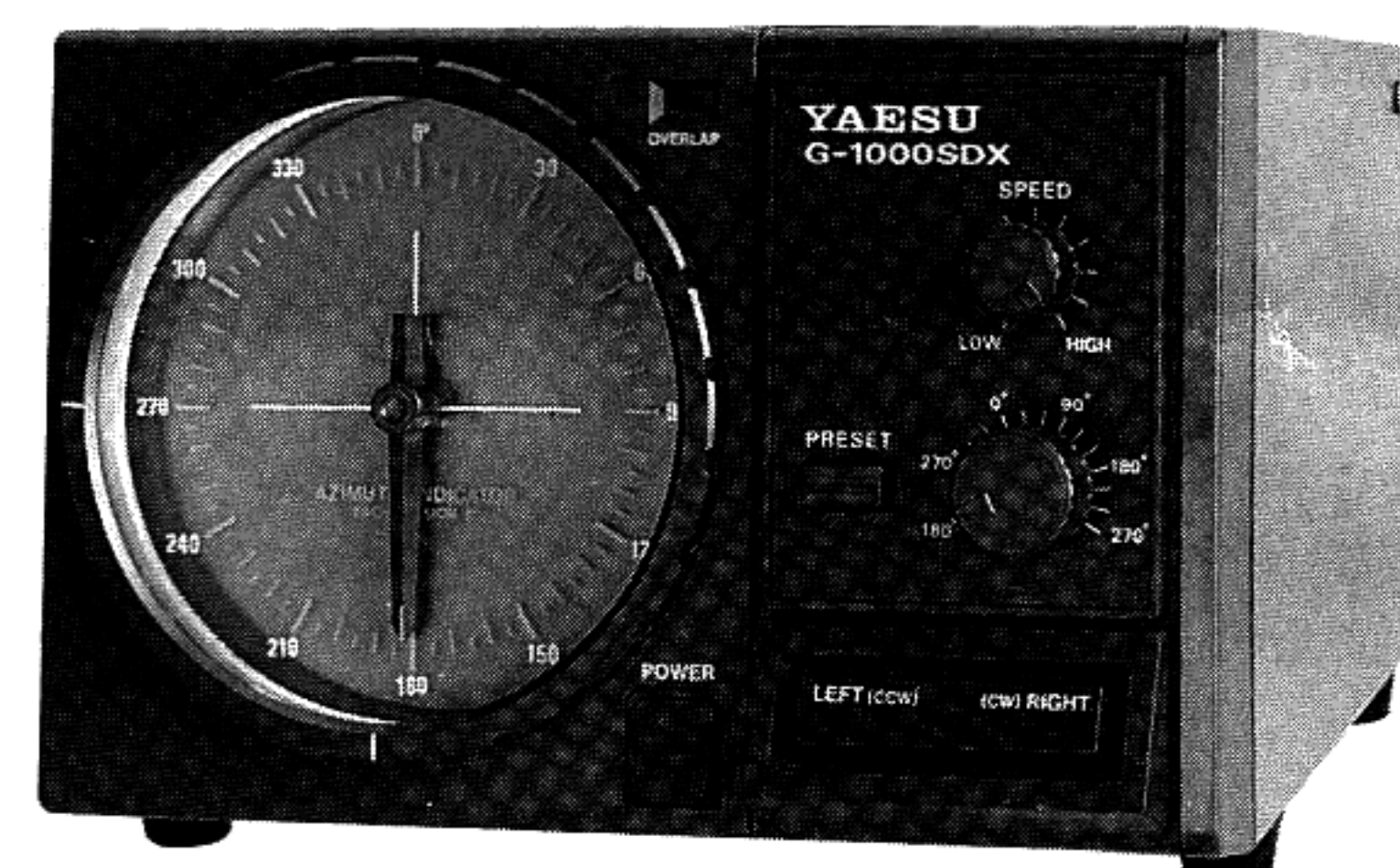

G-1000SDX Controller

The Yaesu G-800S/SDX and G-1000S/SDX are designed to support and rotate medium- to large-size amateur and professional antenna arrays under remote control from the station operating position. The factory-lubricated rotator unit is housed in weatherproof melamine resin coated die-cast aluminum, to provide maintenance-free operation under all climatic conditions. A mast alignment gauge on the rotator housing simplifies accurate mechanical alignment during installation.

The controller unit is a handsomely-styled desktop unit which provides 360° indication of actual antenna bearing azimuth, in both compass direction and degrees. The deluxe SDX versions include operator selectable rotating speeds from 43 to 93 seconds per rotation. Hands-free operation is provided by both S and SDX

versions: the S version having locking direction switches, and the SDX version having a preset feature which brings the antenna around to the preset heading automatically after being set, and slows rotation speed as the antenna approaches the desired heading to bring the antenna to a gentle stop. The operator may select the stopper heading (the bearing through which the rotator cannot be turned) most convenient for his location and operation, allowing full rotation through north, south or both, if desired. In any case, 90° overlapping rotation allows rotation through the selected stopper heading.

Plug connectors are provided on both the rotator and the controller, so cable connection and servicing is simple. Please read this manual carefully before installing the rotator.

Specifications

Voltage requirement:

110-120 or 220-240 VAC

Power consumption:

100 VA

Motor voltage:

S vers.: 20 VDC

SDX vers.: 12 to 22 VDC

450° rotation time:

S vers.: 55 sec.

SDX vers.: 93±10 sec. to 43±15 sec.

Braking torque:

G-1000S/SDX: 6,000 kg-cm (434 ft-lbs)

G-800S/SDX: 4,000 kg-cm (289 ft-lbs)

Rotation torque (all models):

600-1100 kg-cm (43.4-79.5 ft-lbs)

Maximum continuous duty: 5 minutes

Rotation range: 450° +0/-5°

Maximum vertical load:

200 kg (440 lbs)

Wind loading area:

Tower Mounted: less than 0.45 m²

Mast Mounted: less than 2.2 m²

Control cable:

5-conductors: #20 AWG or larger

Mast diameter:

38 - 63mm (1- to 2- inches)

Weight:

G-1000S/SDX Rotator: 3.5 kg (7.7 lbs)

G-800S/SDX Rotator: 3.4 kg (7.5 lbs)

S Controller: 3.2 kg (7.0 lbs)

SDX Controller: 3.6 kg (7.9 lbs)

UNPACKING & INSPECTION

When unpacking the rotator confirm the presence of the following items:

Rotator Unit	1
Controller Unit	1
Mast Clamp	1 pair*
Round Cable Plug	1 ass'y
Rectangular Cable Plug	1 ass'y
Hex Bolts -	
M8 x 16	4
M8 x 25	4
M8 x 70	4
M8 Square Nut	1
Split washer	14
Flat washer	4
M8 Nuts	4
M8 x 95 Socket Hd. Cap Screw	1
Spare Fuse (117V:2A, 220V:1A)	1
Dial Heading Sheet	1

If any of these items are missing or damaged, save the packing material and notify the shipping company (or shop where you bought it).

Note that control cable is not included, as the length must be determined case-by-case. Contact your Yaesu dealer to obtain the length of cable your installation requires.

Before proceeding with installation, confirm that the AC voltage label on the rear of the Controller matches your local line voltage: either "117V" for 110 to 120 VAC, or "220" for 220 to 240 VAC. If the labelled voltage range does not match, return the controller to the dealer from whom you purchased it (different power transformers are installed for the different voltage ranges).

*If you plan to install the rotator on the mast, above or without a tower, contact your Yaesu dealer to purchase a second clamp (model GC-038 or GC-048).

Controller Adjustments & Switches

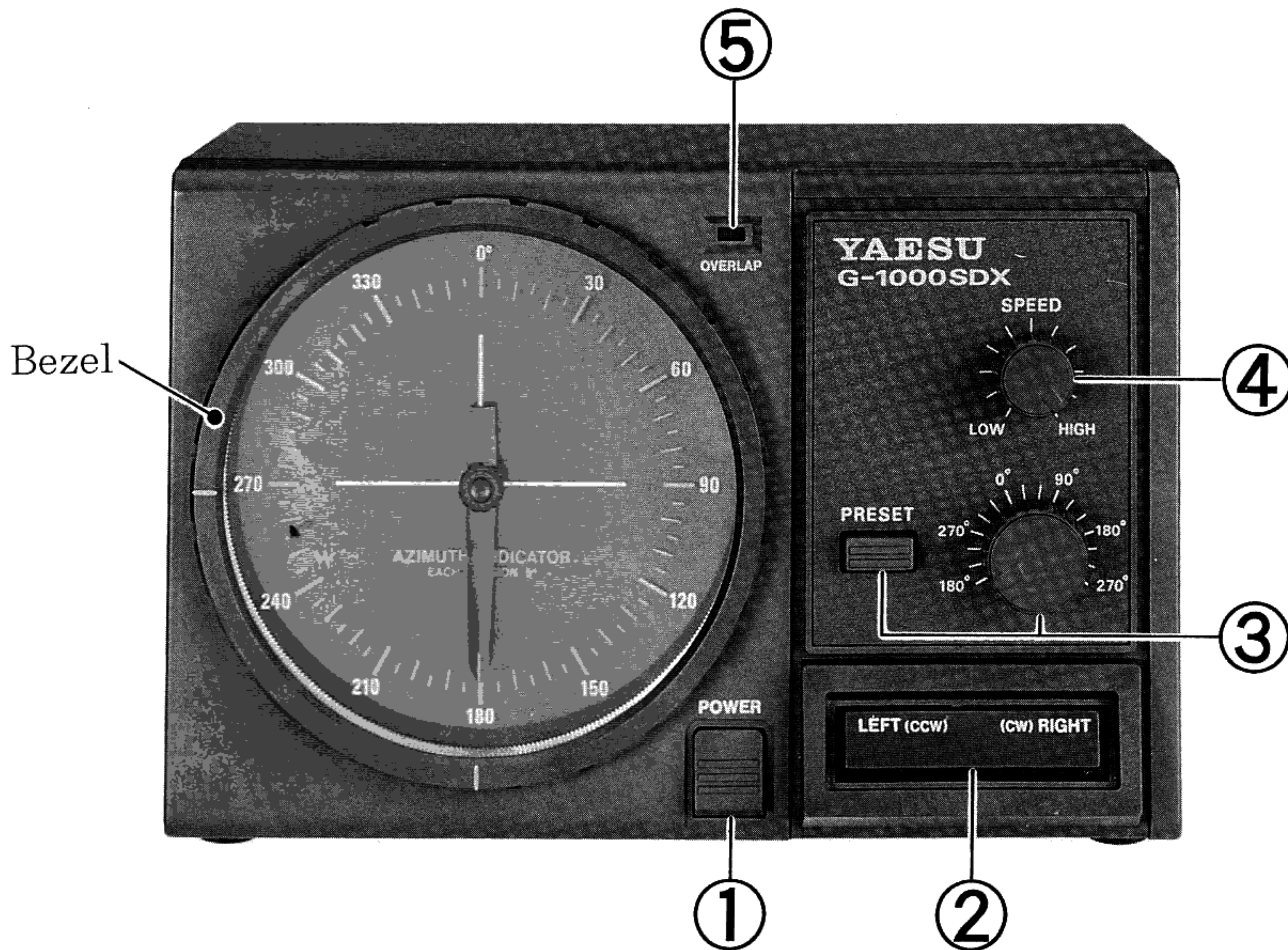

Front

(1) POWER Switch

Press this switch to turn the Controller on to rotate the antenna. Turn it off when the rotator is not in use.

(2) LEFT(ccw) / RIGHT (cw) Seesaw Switch

Press the **LEFT** side of this switch to rotate the antenna counterclockwise. Press the **RIGHT** side to rotate the antenna clockwise. In S versions only, pressing one side of the switch once will start rotation, and pressing the same side again will latch the rotator on (so you can remove your finger). Pressing the other side of the switch once will stop rotation.

(3)* PRESET Switch and Control

Set this control to the desired antenna heading (according to the angular scale around this control), then press the (momentary) **PRESET** switch to activate auto-

matic rotation to the desired heading. The **LEFT/RIGHT** switch will abort preset operation.

(4)* SPEED Control

Set this control for the desired rotating speed between approximately 43 and 93 seconds per 450° revolution.

(5) OVERLAP Indicator

This red LED glows when the antenna is rotated beyond about 180° (to 270°) from its original installation direction (180°). Check this indicator before rotating the antenna clockwise, and turn the antenna counterclockwise to the desired position if the indicator is on.

*SDX versions only.

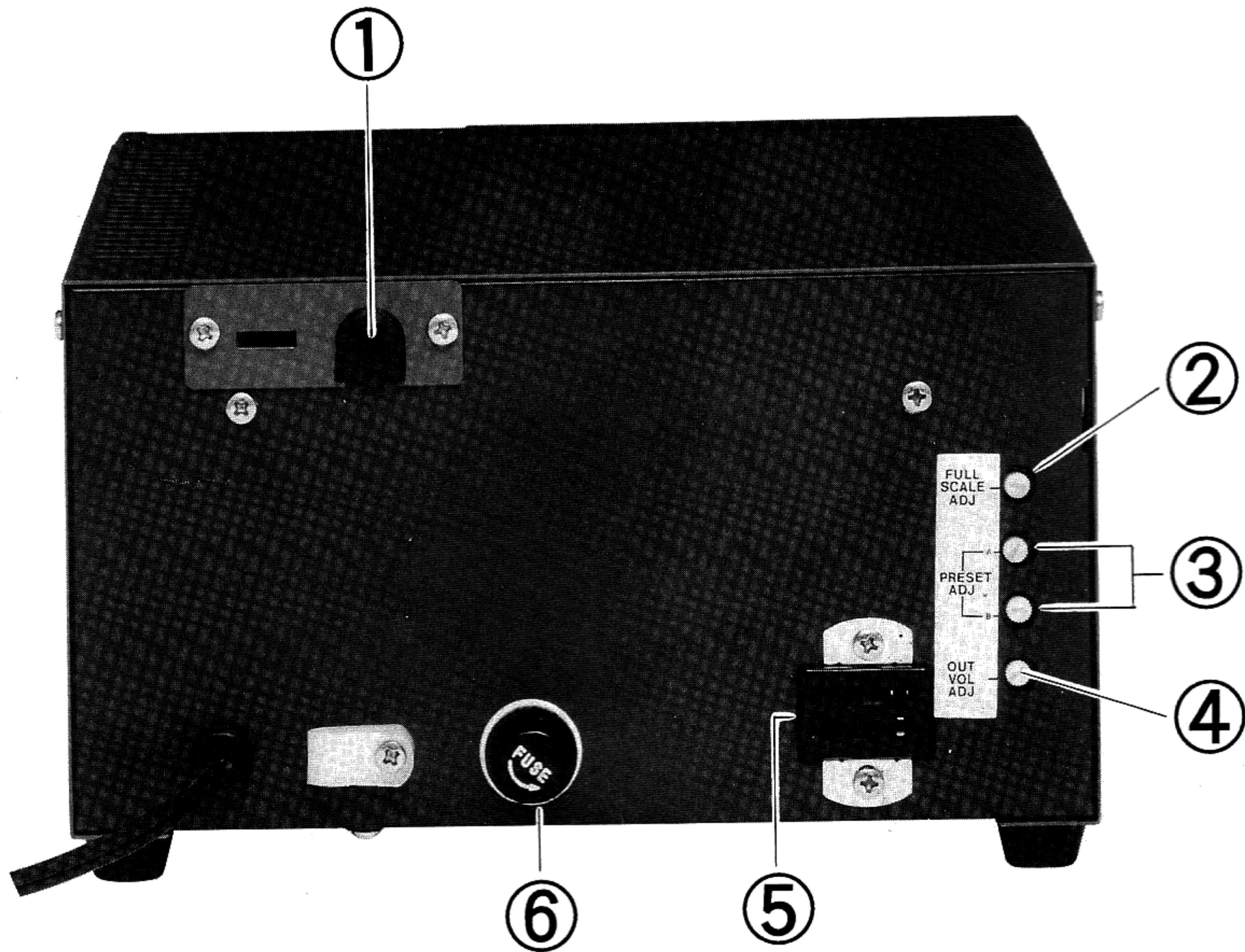

Rear

(1)* RS-232C Cable Grommet

If the optional Digital Interface Unit is installed, the RS-232C cable to the computer exits through this grommet and passes through the nylon cable clamp below it.

(2) FULL SCALE ADJ Potentiometer

This control calibrates the maximum rotation angle of the azimuth indicating needle to match the maximum angle of the rotator.

(3)* PRESET ADJ A & B Potentiometers

These controls calibrate the angle of the PRESET control on the front panel to match the azimuth indicating needle. Pot A must be adjusted only at the 270° position, and pot B only at the 180° position.

(4)* OUT VOL ADJ Potentiometer

This control presets the voltage range at pin 4 of the 8-pin External Control jack inside, for calibration of the A-to-D converter on the (optional) Digital Interface Unit.

(5) Rotator Control Cable Jack

The rotator cable connects to this 6-pin jack.

(6) FUSE Holder

A 2-A fuse must be installed here for AC mains voltages from 110 to 120V. A 1A fuse must be installed for 220 to 240V.

*SDX versions only

Control Cable Installation

Before installing the antenna and rotator, prepare the rotator control cable and test rotator operation thoroughly on the ground as described here. We recommend that after this you also check the alignment of the controller, as described in the following section.

Control Cable Preparation

Your control cable should have five stranded conductors of at least 0.5mm (#22 gauge) if the cable is shorter than 40m (125'), or 0.75mm (#18 gauge) if longer.

1. Disassemble the two supplied cable plugs: slide the rubber boot off the round plug, remove the setscrew in the shell with a small screwdriver, and then unscrew the shell from the plug. On the rectangular plug, just remove the two small screws in the shell. Save the setscrew from the round plug and the two small screws in a safe place until step 9, so you don't lose them.

2. Slide the rubber boot and round shell over the rotator end of the cable, far enough to allow dressing the end of the cable. Slide the rectangular shell over the other (controller) end of the cable.

3. Using special care to avoid nicking the insulation of the individual wires, strip back 15mm of the outer jacket of the cable from both ends, and then strip 5mm of insulation from each wire.

4. Solder the wires to the round plug pins, noting the color of the wire and number of each pin for reference later. Pin 6 (center pin) is not used. Confirm all solder

joints are good and clean, as this part of the cable will be hard to access after installation. Don't slide the shell on yet.

5. Referring to your notes of the wire color at each pin on the round (rotator) plug, connect the wires to the pins of the rectangular (controller) plug so that the wire from each pin on the rotator plug connects to the pin with the same number on the controller, ie., 1 to 1, 2 to 2, etc. Pin 6 is not used. Don't slide the shell on yet.

6. Temporarily connect the round plug to the rotator, and the rectangular plug to the jack on the controller. Make sure that the **POWER** switch is in the off (out) position, and then connect the cord to the AC power outlet.

7. Turn on the **POWER** switch. The pilot lamps should light, and the direction indicator move to the position of the rotator and stop.

8. Press the **LEFT** side of the seesaw switch, and confirm that the rotator (when viewed from the top) and indicator needle turn counterclockwise together. Then press the **RIGHT** side of the seesaw switch and confirm that the rotator and indicator turn clockwise. If rotation does not occur as described, recheck your cable connections.

9. If the rotator and indicator work as described, replace the plug shells, setscrew, two small screws and rubber boot removed in step 1.

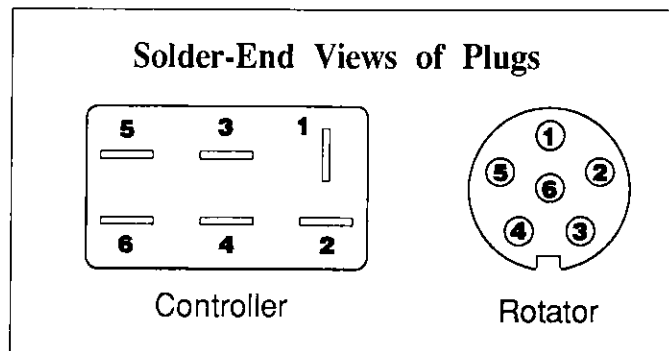

Controller Checkout & Alignment

These steps are most easily carried out after connecting the rotator cable, before installing the rotator and antenna on the mast or tower. They may be repeated after installation to confirm controller calibration.

1. Press the **LEFT** side of the seesaw switch* until the rotator turns counterclockwise as far as it will go, and stops. The indicator needle should now point precisely to 180°. If it does not, or if you want to change the starting angle, see "*Repositioning the Direction Indicator*" following this procedure.

2. Note the precise position of the rotator** by referring to the marks on the rotator housing just above the cable socket. Then press the **RIGHT** side of the seesaw switch to turn the rotator clockwise exactly 180° (according to the marks on the housing or actual antenna position).

3. The indicator needle should now point to exactly the same position as in step 1. If not, adjust the **FULL SCALE ADJ** potentiometer on the rear panel so that it does. The **OVERLAP** indicator should come on at about 180°.

4. Press the **RIGHT** switch again to continue clockwise rotation until the rotator reaches its end-stop. The indicator should now point to about 270°, and the **OVERLAP** indicator should be on.

5. Turn the rotator back and forth to each end-stop several times, confirming that the indicator matches the rotator angle at different settings.

The remaining steps on this page are for the SDX versions only.

6. Change the **SPEED** setting and confirm that rotation speed changes accordingly.

7. Set the **PRESET** control to 180° (7 o'clock), and press the **PRESET** button (see the box below). Rotation should stop at 180°. Now turn the **PRESET** control slightly clockwise, and note whether the rotator moves. If the rotator stopped before the indicator reached 180°, or if it did not respond when the **PRESET** control was set slightly clockwise, adjust the **PRESET ADJ B** (lower) potentiometer and repeat this step.

8. Set the **PRESET** control to 180° (2 o'clock). Rotation should again stop at 180°. If not, adjust the **PRESET ADJ A** (upper) potentiometer and repeat this step.

PRESET MODE OPERATION (SDX versions only)

Pressing the **PRESET** button activates the preset mode: the rotator will turn until the indicator matches the **PRESET** control, and resetting the control will start the antenna turning again automatically. Pressing the seesaw switch or turning power off will cancel the preset mode until the **PRESET** button is pressed again.

*In SDX versions, set the **SPEED** control fully clockwise, and then hold the seesaw switch during rotation. In S-versions, press the seesaw switch momentarily to start rotation, and press the other side of the switch to stop.

**If the rotator and antenna are already installed, note the exact bearing of the antenna boom instead of the marks on the rotator housing.

Repositioning the Azimuth Indicator

The azimuth indicating needle may be repositioned, if desired, so that the rotator stopping point is south (or east or west) instead of north (as shipped from the factory). Of course the rotator and antenna will have to be installed to match the direction indicator.

1. Turn on the controller and press the seesaw switch to set the indicator needle to 180° (straight down). Then turn off the **POWER** switch.

2. Grasp the edge of the bezel, turn it 10° counterclockwise, and pull it off.

3. Gripping the needle, move it to the desired heading (we suggest only multiples of 90° - that is N, E, S or W, since the orange and blue markers on the bezel can only be installed in these directions).

4. Replace the bezel so that the orange marker ends down aligned with the needle.

NOTE: When installing the antenna after resetting the needle direction, make sure to aim the antenna in same direction as the new needle setting.

The compass heading labels can also be repositioned on the direction indicator face, for situations where it may

be more convenient to have the upmost indicator position be other than north.

- Perform steps 1 and 2 of the procedure at the left.
- Note the position of the needle, then grasp it at its center, and pull it straight off.
- Push the E and W (or N and S) sides of the compass heading label sheet towards the center, and remove the sheet.
- Determine which compass direction you desire to be upmost, and reinstall the compass heading label sheet.
- Replace the needle and bezel in the same direction as they were before.

PRESET Knob Alignment (SDX vers. only)

If it is not possible to calibrate the **PRESET** knob using the A and B potentiometers on the rear panel, pull off the **PRESET** control knob, turn the shaft fully counterclockwise, and reinstall the knob with its pointer at 180° on the **PRESET** scale. The knob stopper should be aligned with the counterclockwise edge of the slot in the panel behind the knob.

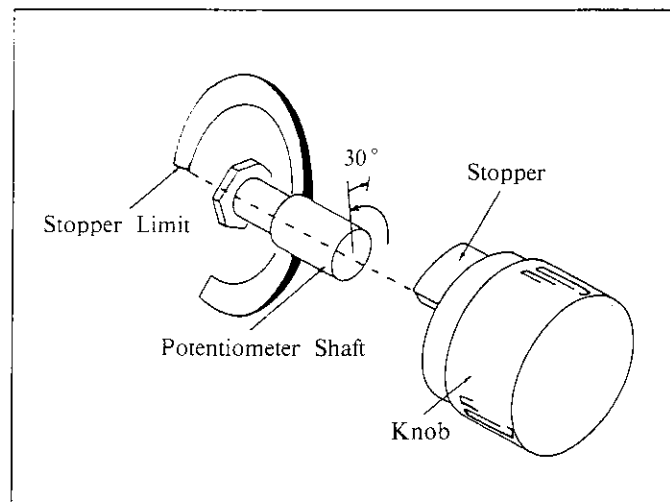

Installing the Dial Heading Sheet

A clear plastic round dial heading sheet is provided with the kit, which can be installed with north at any position you desire. This is particularly useful when you need to have south at the top of the dial (or east or west) instead of north. To install the heading scale:

- Perform the first two steps of the above procedure, "*Repositioning the Azimuth Indicator*".
- Note the position of the needle, then grasp it at its center, and pull it straight off.
- Determine which compass direction you desire to be upmost, and install the compass heading label sheet against the azimuth scale, so that the small teeth in the edges of the sheet lock around the edge.

Replace the needle, cover glass and bezel in the same direction as they were before.

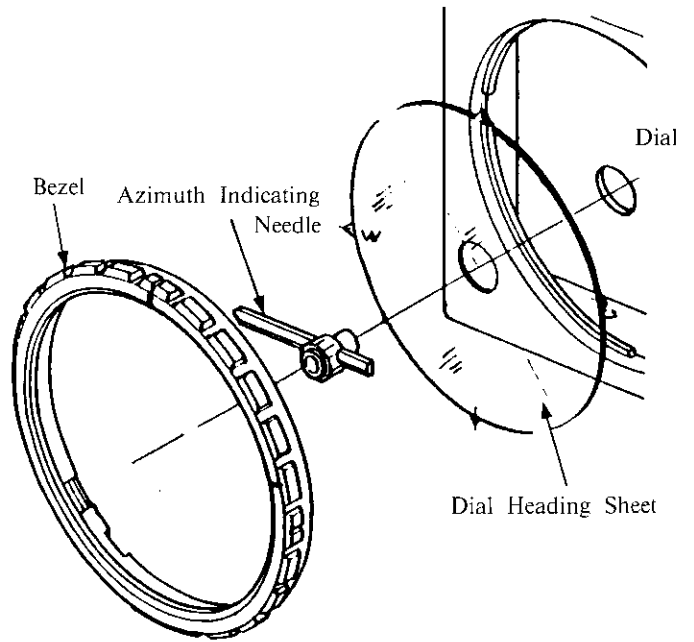

Rotator Installation

The G-800S/SDX rotator unit is designed to accommodate medium-size antenna arrays, while the G-1000S/SDX rotator unit is designed to accommodate large antenna arrays. The maximum safe load depends on the wind surface area, size and weight of the antenna(s), method and quality of mechanical installation, and maximum wind velocity at the installation site. If your antenna specifications do not include wind surface area, refer to the Chart on this page.

The diagrams below show several recommended installations. Notice that mounting the rotator inside of a tower provides the greatest support capacity (antenna wind surface area up to 2m for the G-800S/SDX, or 2.2m for the G-1000S/SDX), and is preferable for larger antennas or in high-wind areas. Use our GS-050 or GS-065 Tower Mount Bearing at the top of the tower (and make sure that the bearing is aligned precisely with the center of the rotator, so the mast is exactly vertical).

If the rotator is mounted on the mast above the tower it should be as close to the antenna as possible, to minimize the stress on the rotator caused by wind pressure against the antenna. This bending force on the rotator limits the supporting capacity of this type of installation to antennas with not more than $0.45/Lm$ square meters of

wind surface area, where Lm is the length of mast (in meters) between the antenna and rotator.

In addition to antenna wind loading and regardless of the type of installation, the overall size and weight of the antenna should be considered. As a general rule, for the G-800S/SDX, the product of the rotating radius and weight of the antenna should not exceed 180 kg-m (1299 ft-lbs), and for the G-1000S/SDX, 230 kg-m (2020 ft-lbs).

Where multiple antennas are to be installed on the same mast, make sure to add the wind loading for each antenna, and the products of weight and radius for each when calculating the above loading factors.

Make certain that the antenna attaches to the mast at the center of gravity of the antenna. That is, the antenna should be balanced, providing only downward force on the mast (when there is no wind). These rotators can support up to 250 kg (550 lbs).

Be sure to leave enough slack in the coaxial cable feedline around the rotator so that it can rotate 450°.

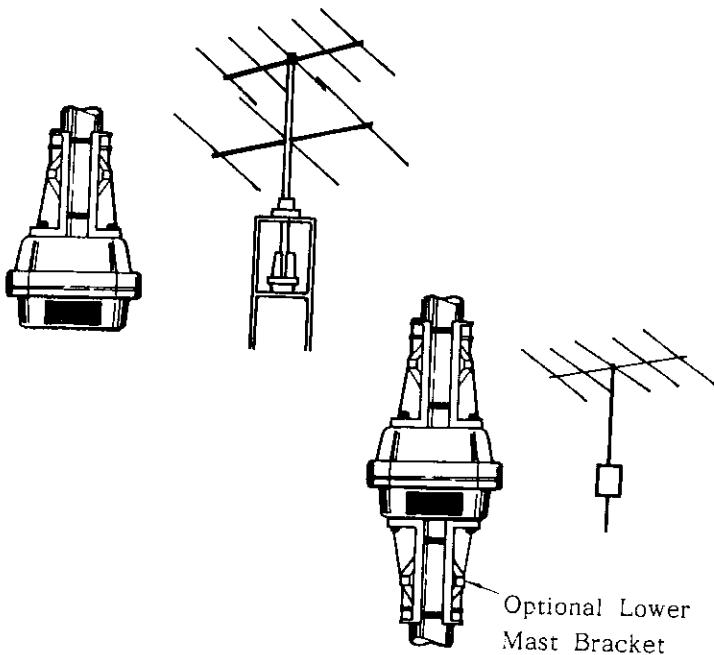

Antenna Wind Surface Area Chart

Freq. (MHz)	Elements	Area m ²	Freq. (MHz)	Elements	Area m ²
7	2	2.2	14/21	3 Tr	0.4
7	1	0.2	14/21	4 Tr	0.5
7	2 Lc	0.6	21/28	3 Tr	0.3
7	3 Lc	1.1	21/29	4 Tr	0.4
14	3	0.7	14/21/28	3 Tr	0.4
14	4	1.2	14/21/28	4 Tr	0.4
14	5	1.7	50	4	0.25
21	3	0.45	50	5	0.3
21	4	0.6	50	6	0.37
21	5	0.8	50	2 SQ	0.3
21	6	1.3	144	10	0.2
21	2 SQ	0.3	144	10 x 2	0.44
28	3	0.3	144	10 x 4	0.95
28	4	0.42	144	10 x 2 x 4	2.0
28	5	0.6	430	12	0.06
28	2 SQ	0.3	430	12 x 2	0.12
7/14	3 Tr	0.5	430	12 x 4	0.3
7/14	4 Tr	0.8	430	12 x 2 x 4	0.6

* Lc = with loading coils
 SQ = Swiss Quad configuration
 Tr = Trapped multibander
 No marking = full-size monobander

Mast Bracket Assembly & Antenna Positioning

Important!! Before mounting the mast to the rotator, a single hole must be drilled through the bottom of the mast to accommodate an anti-twist support bolt:

- ❑ Drill a 9-mm diameter hole through both walls of the mast, centered 50 mm from the mast bottom (as shown in the figure below). Ensure the drill is maintained perpendicular and centered when making the hole, to ensure proper alignment of the holes in the mast and those of the base mast support bracket.
- ❑ Loosely fasten the mast bracket halves (1) to the rotator housing using four short bolts, split washers and flat washers (2).
- ❑ Insert the mast into the bracket and turn it so the holes in the mast bottom coincide with those in the base support clamp. Insert and finger-tighten the five longer bolts (3) with split washers, flat washers and nuts (4).
- ❑ Set the controller so that it indicates precisely 0° (North). Then, using an accurate map and known landmarks, position the antenna (without using the controller) so that it points to true North. Alternatively, consult a Geodetic Survey map for your area to determine the Magnetic Deviation at your location, and then use a compass to position the antenna so that it points to true North (Magnetic North + Magnetic

Caution!

The G-800 and G-1000 rotators are designed for vertical mounting only. One half of the housing is marked "TOP SIDE". Water and contaminants will damage the motor unit if it is mounted horizontally or upside-down.

Deviation). Be careful not to disturb the antenna direction when tightening the mast bracket in the next step.

- ❑ Referring to the mast gauge markings on the rotator housing, tap the mast bracket halves to center the mast while alternately tightening the short bolts (2) and nuts (4) on the long bolts alternately.

Warning!!

Take care not to overtighten the five clamp bolts. Do not torque the bolts beyond the point where the spring split-washer flattens.

The rotator motor is rated for five-minutes intermittent duty. However, it can safely run continuously for as long as ten minutes providing that it be brought to rest for at least ten minutes afterwards.

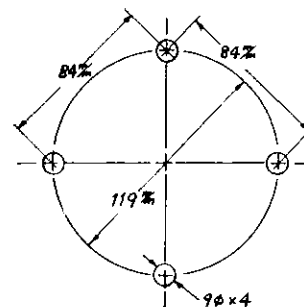
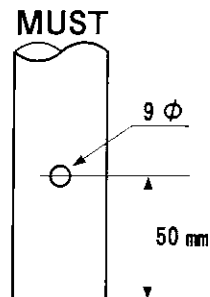
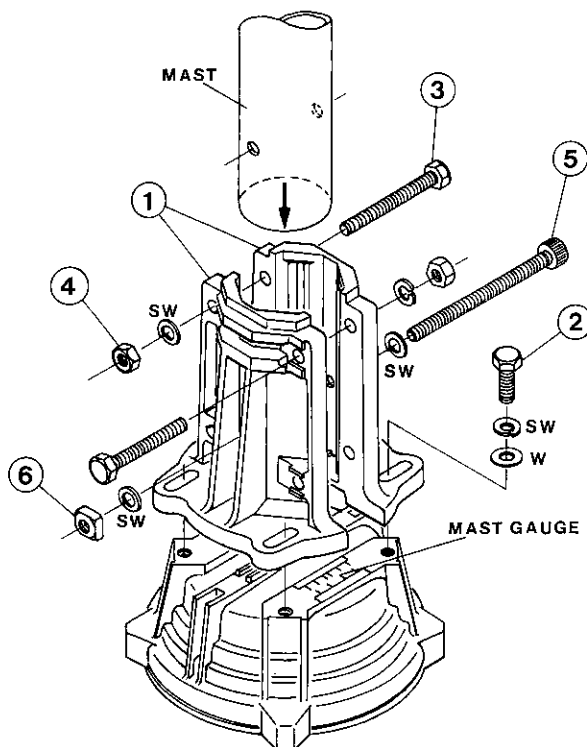

Parts List

Rotater Unit

Ref. No.	Part Description	Part No.	Ref. No.	Part Description	Part No.	Ref. No.	Part Description	Part No.
1	Lower Housing	S8000360	22	2.5 mm E-Ring	S8000380	43	Pot. Lock Washer	Q9000420
2	Upper Housing	S8000361	23	Gearshaft (x3)	-	44	Pot. Nut	Q9000420
3	M6 Split Washer (x4)	S8000362	24	Gear Assembly A	S8000381	45	Pot. Gear #1	S800397
4	M6 x 20 Screw (x4)	S8000363	25	Gear Assembly C	S8000382	46	Pot. Gear Setscrew	S800398
5	Ball Bearing	S8000364	26	Sandwich Gear #1 *	S8000383	47	Pot. Gear #2	S800399
6	Socket Gasket	S8000365	27	Gear Assembly A **	S8000384	48	Mast Clamp	S800400
7	Socket	S8000366	28	Sandwich Gear #1 **	S8000385	49	M8 x 70 Bolt	S800401
8	3 x 10 Tapping Screw (x3)	S8000367	29	Divider Gear #1	S8000386	50	8mm Split Washer	S800402
9	Inner Housing Seal Plate	S8000368	30	Divider Gear #2 *	S8000387	51	M8 Nut	S800403
10	Binding Screw (x2)	S8000369	31	Divider Gear #2 **	S8000388	52	8 mm Washer	S800404
11	Inner Housing	S8000370	32	Spacer Bushing	S8000389	53	8 mm Split Washer	S800405
12	M3 x 8 Screw	S8000371	33	Upper Gearbox Plate	S8000390	54	M8 x 25 Bolt	S800406
13	DC Motor	M2190017	34	M6 x 6 Bolt (x4)	S8000391	55	Ring Housing	S8001173
14	Motor Mount Plate	S8000372	35	Rotation Limiter	S8000392	56	Brake Drum	S8001174
15	M3 x 6 Screw (x3)	S8000373	36	Retainer Ring	S8000393	63	M8 x 95 Socket Hd. Cap Screw	S8001175
16	Lower Gearbox Plate	S8000374	37	Limit Switch	N7090087	64	M8 Square Nut	S8001176
17	M3 x 8 Screw (x4)	S8000375	38	M3 x 16 Screw	S8000394			
18	Coil Spring	S8000376	39	Pot. Mounting Plate	S800395		Notes:	
19	Spring Washer	S8000377	40	Binding Screw	S800396		* used w/G-1000	
20	M3 x 3 Setscrew	S8000378	41	Potentiometer	Q9000420		** used w/G-800	

OPTIONAL PARTS

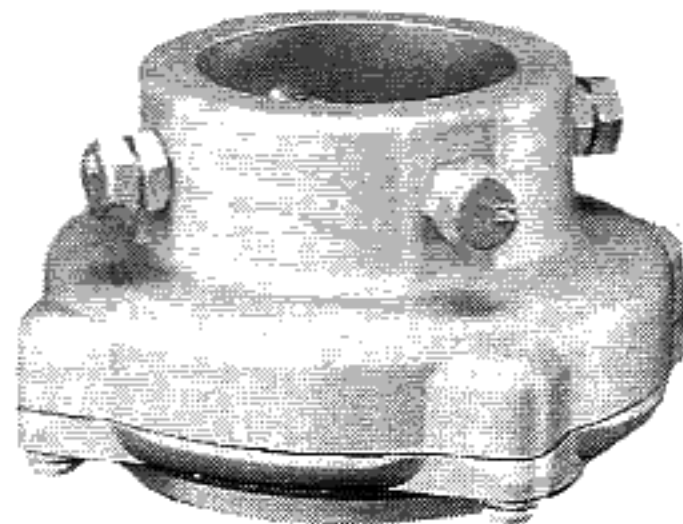

**GS-050 50mm
Thrust Bearing**

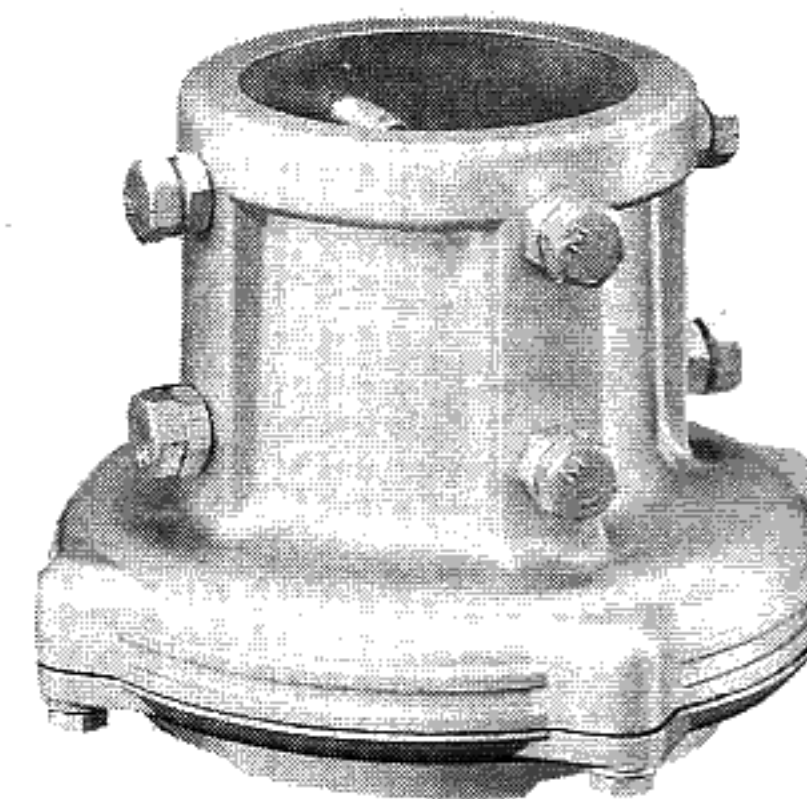

**GS-065 65mm
Thrust Bearing**

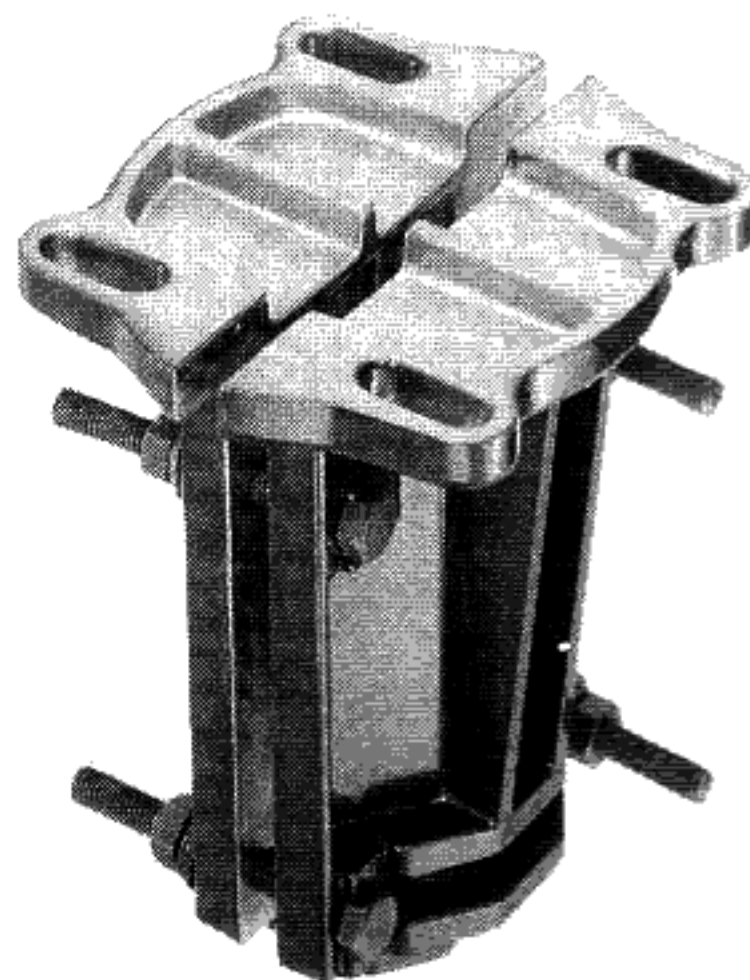

**GC-038
Mast Clamp**

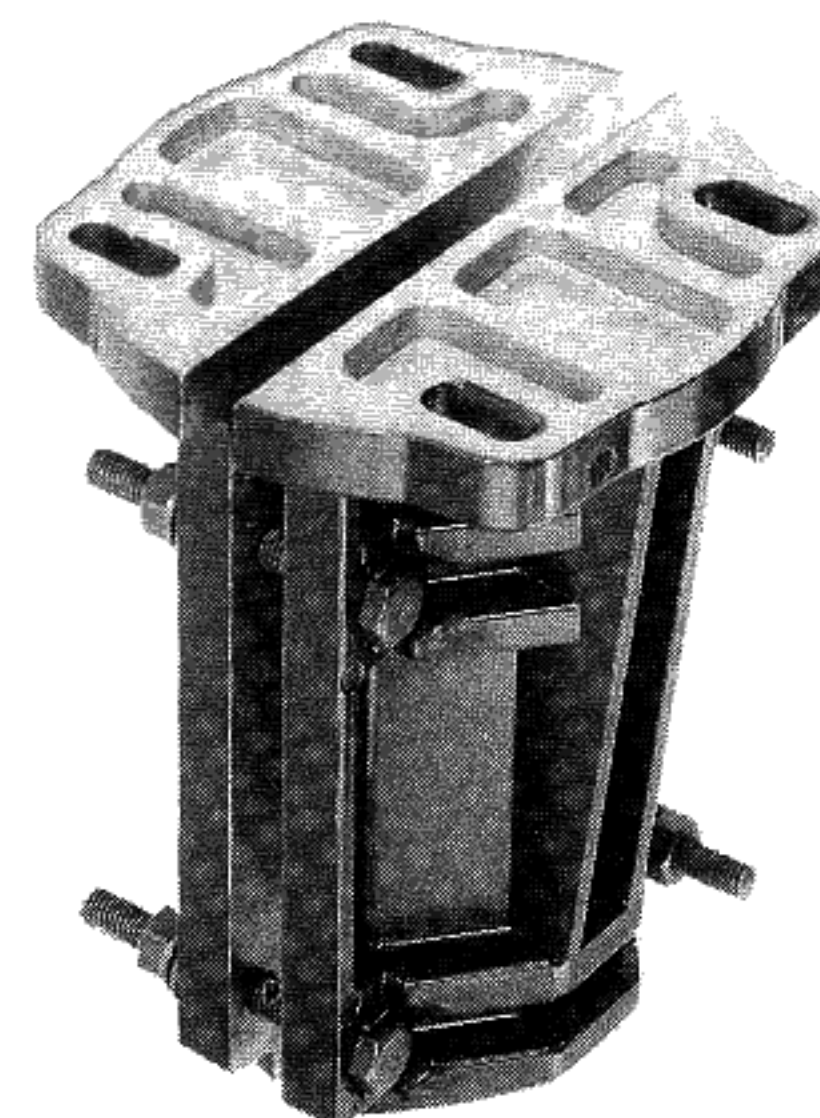

**GC-048
Mast Clamp**

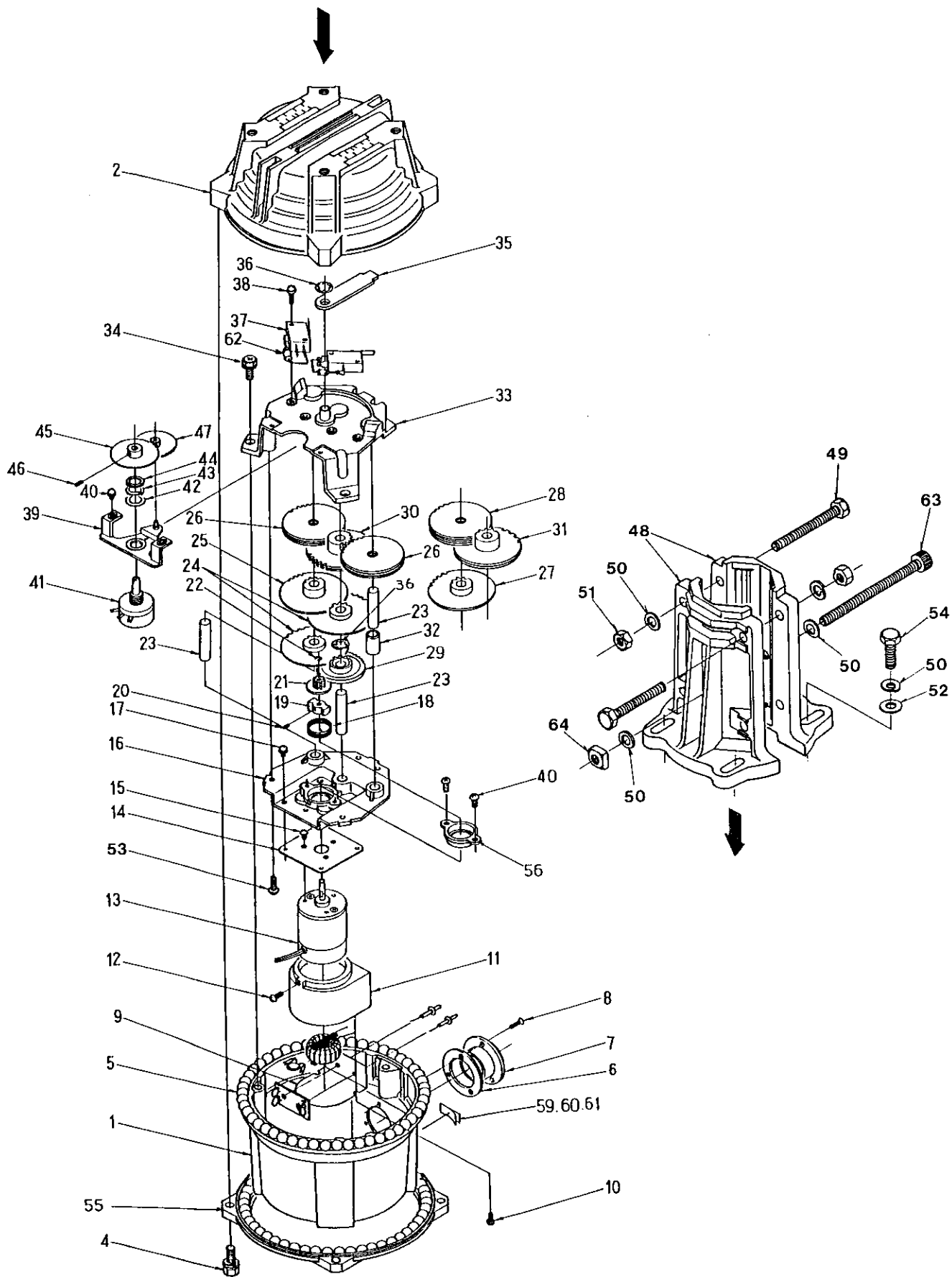

Controller Unit

Ref. No.	Model Unit	S	SDX	Qty.	Part Description
1	S/SDX	S8000407	S8000440	1	Front Panel
2	S/SDX	S8000408	S8000441	1	Switch Panel
3	S/SDX	S8000834	S8000834	4	3 x 8 Screw
4	SDX		S8001189 S8001190	1	Switch Panel Name Plate for G-800SDX Switch Panel Name Plate for G1000SDX
5	S	R8123320 R8123330		1	Switch Panel Name Plate for G-800S Switch Panel Name Plate for G1000S
6	SDX		S8000442	1	Speed Control Knob
7	SDX		S8000859	1	VR Nut
8	SDX		S8000860	1	VR Washer
9	SDX		Q9000425	1	Speed Control VR
10	SDX		S8000444	1	Preset Knob
11	SDX		S8000861	1	VR Nut
12	SDX		S8000862		VR Washer
13	SDX		Q9000426	1	Preset VR
14	SDX		S8000444	1	Reset Knob
15	SDX SDX SDX		N7090084 N7090085 N7090086	1	"L-R" Rotation Switch "L-R" Rotation Switch Reset Switch
16	SDX		Q9000488	1/4	PC Board # 1
17	SDX		S8000863	2	3 x 8 Screw
18	S/SDX	S8000409	S8000445	1	"L-R" Knob
19	S/SDX	S8000410	S8000446	1	Switch Spring
20	S/SDX	S8000835	S8000835	1	3 x 8 Screw
21	S/SDX	S8000411	S8000447	1	L/R Knob Fixing Metal
22	S/SDX	S8000836	S8000836	1	3 x 8 Screw
23	SDX		S8000864	1	L/R Switch Mounting Plate
24	S/SDX	S8000837	S8000837	2	3 x 8 Screw
25	SDX		Q9000488	1/4	P.C. Board #2
26	SDX		S8000865	2	3 x 6 Screw
27	S	S8000412		1	L/R Switch Mounting Plate
28	S	N7090078 N7090079		1 1	L/R Switch L/R Switch
29	S	S8000854		4	M2.3 x 10 Screw
30	S	S8000413		1	Lock Spring Mounting Metal
31	S	S8000855		2	3 x 8 Screw
32	S	S8000414		1	Lock Spring
33	S	S8000856		1	3 x 6 Screw
34	S/SDX	S8000415	S8000448	1	Power Switch Knob
35	S/SDX	S8000416	S8000449	1	Power Switch Mounting Plate
36	S/SDX	S8000838	S8000838	2	3 x 8 Screw
37					
38	S/SDX	S8000839	S8000839	2	M3 x 6 Screw
39	S/SDX	N7090074	N7090080	1	Power Switch
40	S/SDX	G2090418	G2090418	1	LED

Ref. No.	Model Unit	S	SDX	Qty.	Part Description
41	S/SDX	S8000417	S8000450	1	Bezel
42	S/SDX	S8000418	S8000451	1	Clear Cover
43	SS/DX	S8000419	S8000452	1	Dial Scale
44	S/SDX	S8000840	S8000840	3	3 x 10 Screw
45	S/SDX	S8000420	S8000453	3	Dial Plate Spacer
46	S/SDX	S8000421	S8000454	1	Dial Mounting Plate
47	S/SDX	S8000841	S8000841	4	3 x 8 Screw
48	S/SDX	S8000422	S8000455	1	Indicator Needle
49	S/SDX	S8000423	S8000456	1	Control Gear #2
50	S/SDX	S8000424	S8000457	1	Control Gear #1
51	S/SDX	S8000425	S8000458	1	Insulation Bush
52	S/SDX	S8000842	S8000842	1	"E" Ring 02
53					
54	S/SDX	S8000426	S8000459	1	Large Pulley
55	S/SDX			1	Gear Shaft (installed in No. 64 Gear Base)
56	S/SDX	S8000427	S8000460	1	Small Pulley
57	S/SDX	S8000428	S8000461	1	Rubber Belt
58	S/SDX	M2190015	M2190015	1	DC Motor
59	S/SDX	S8001019	S8001019	2	M2.6 x 5 Screw
60	S/SDX	S8000429	S8000462	1	VR Gear
61	S/SDX	S8001020	S8001020	1	M3 x 3 VR Gear Setscrew
62	S/SDX	S8001021	S8001021	1	VR Nut w/Washer & Split Washer
63	S/SDX	Q9000422	Q9000422	1	Potentiometer
64	S/SDX	S8000430	S8000463	1	Gear Base (Incl. No. 55, 77)
65	S/SDX	S8000843	S8000843	4	3 x 6 Screw
66	S/SDX	N7090075	N7090081	1	3p Leaf Switch Assembly (Incl. No. 67 - 76)
67-76					
77	S/SDX			1	Stud (installed in No. 64 Gear Base)
78	S/SDX	Q9000478	Q9000487	1	P.C. Board #5
79	S/SDX	S8000844	S8000844	4	M3 x 6 Screw
80	S/SDX	S8000431	S8000464	1	Chassis
81	S/SDX	S8000845	S8000845	3	3 x 8 Screw
82	S/SDX	S8000846	S8000846	2	3 x 6 Screw
83	S/SDX	L3190010	L31900012	1	
84	S/SDX	S8000847	S8000847	2	M4 x 10 Screw
85	S/SDX	S8000848	S8000848	2	M4 Nut
86					
87	SDX		Q9000488	1/4	P.C. Board #3
88	S	Q9000479		1	P.C. Board #6
89	SDX		S8000866	4	3 x 6 Screw
	S	S8000857		2	3 x 6 Screw

Ref. No.	Model Unit	S	SDX	Qty.	Part Description
91	S/SDX	P2000038 Q0000002 Q0000003	P2000039 Q0000002 Q0000003	1	Fuse Holder (incl. No. 91 - 93) Fuse (220 V) Fuse (117V)
91-93					
94	S/SDX	S8000432	S8000465	1	Control Cable Socket
95	S/SDX	S8000849	S8000849	2	3 x 6 Screw
96	SDX	S8000434	S8000466	1	Cord Clamp
97	SDX		S8001022	1	3 x 8 Screw
98	SDX		S8001023	1	Expansion Board Rear Cover
99	S/SDX	S8000850	S8000850	2	3 x 6 Screw
100	S/SDX	S8000433	S8000467	2	Rubber Grommet
101	S	S8000435		1	Blind Cover
102	SDX		S8000469	1	Heat Sink
103	SDX		S8000867	2	3 x 6 Screw
104	SDX		G3090014	1	Transistor
105-110					
111	SDX		G2090437	1	Bridge Diode
112	SDX		S8000868	1	3 x 12 Screw
113	SDX		S8000869	1	Expansion Board Chassis
114	S/SDX	S8000851	S8000851	2	3 x 6 Screw
115	SDX		S8000870	2	M3 x 6 Screw
116	S	S8000436		2	Front Panel Supporting Plate
117	SDX		Q9000488	1/4	P.C. Board #4
118	SDX		S8001024	2	3 x 6 Screw
119	SDX		S8000871	1	3 x 6 Screw
120	SDX		S8000872	1	3 x 6 Screw
121	S/SDX	S8000437	S8000471	1	Cover
122	S/SDX	S8000438	S8000472	4	Rubber Foot
123	S/SDX	S8000852	S8000852	4	3 x 8 Screw
124	S/SDX	S8000853	S8000853	2	Eyelet w/Lug Terminal
125	S/SDX	Q1000069	Q1000070	1	Axial Lamp
126-127					
128	S/SDX	S8001026	S8001026	1	Bushing
129	S/SDX	S8000439	S8000473	1	Direction Sheet (Accessory)
130	SDX		A0458001	1	Expansion Board (option=GS-23)
131	SDX		S8000873	4	3 x 8 Screw
132	S	S8000858		2	3 x 8 Screw for S version
133	S/SDX	S8100274 S8100275	S8100274 S8100275	1 1	Power Cord for 220V Power Cord for 117V

**G-800S/G-1000S
G-800SDX/G-1000SDX**

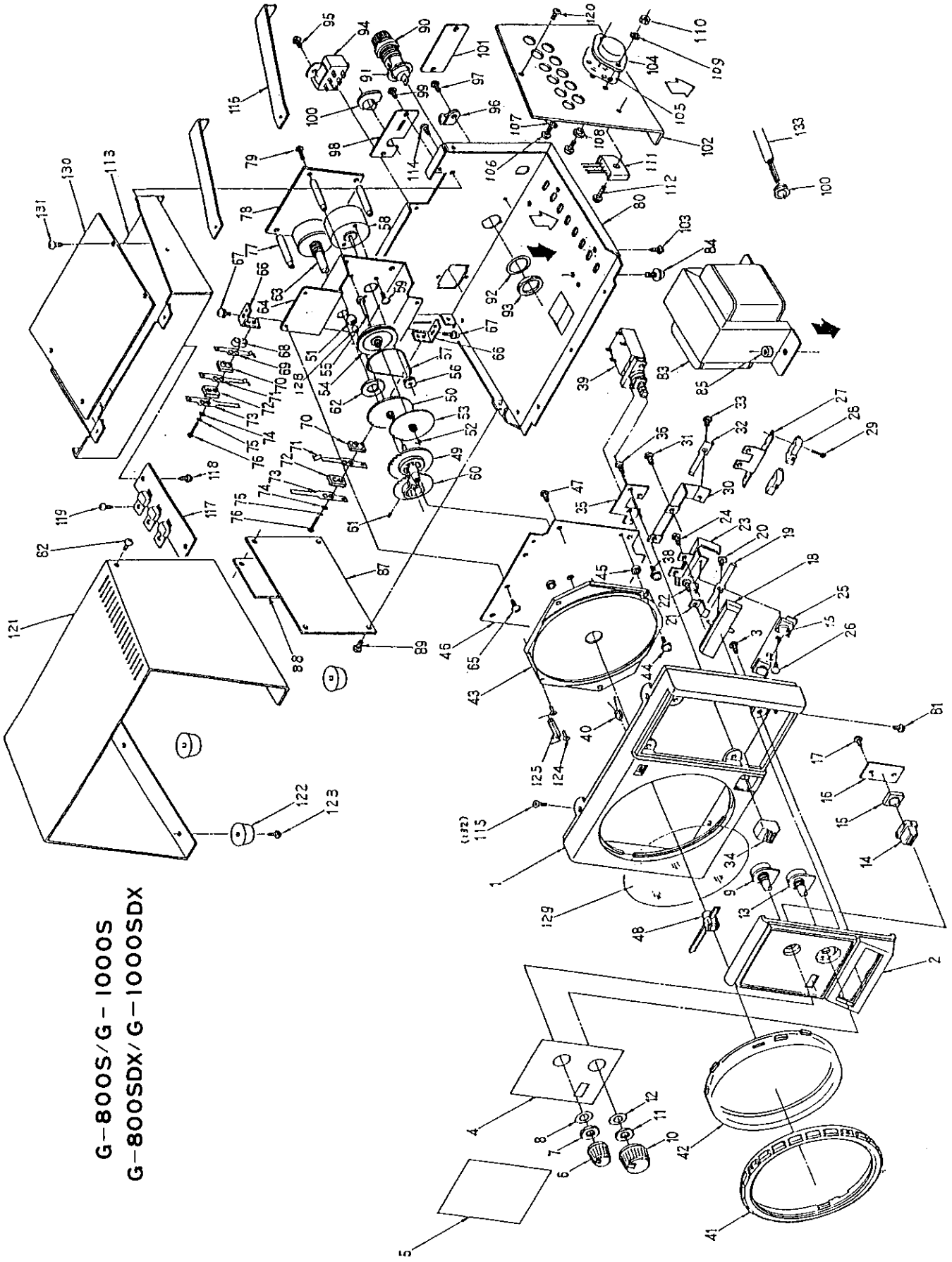

G-800S/G1000S SCHEMATIC DIAGRAM

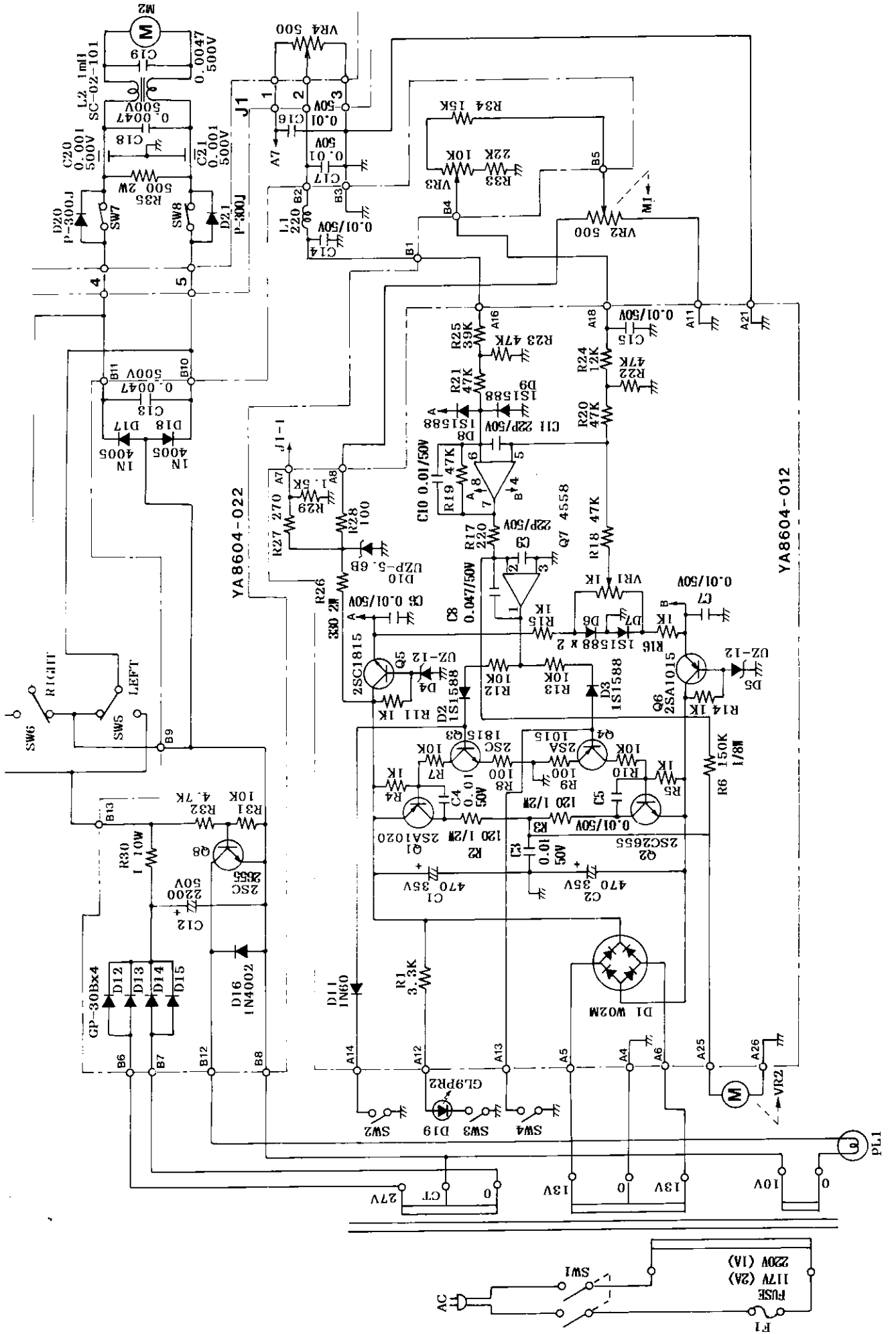

G-800SDX/G1000SDX SCHEMATIC DIAGRAM (1)

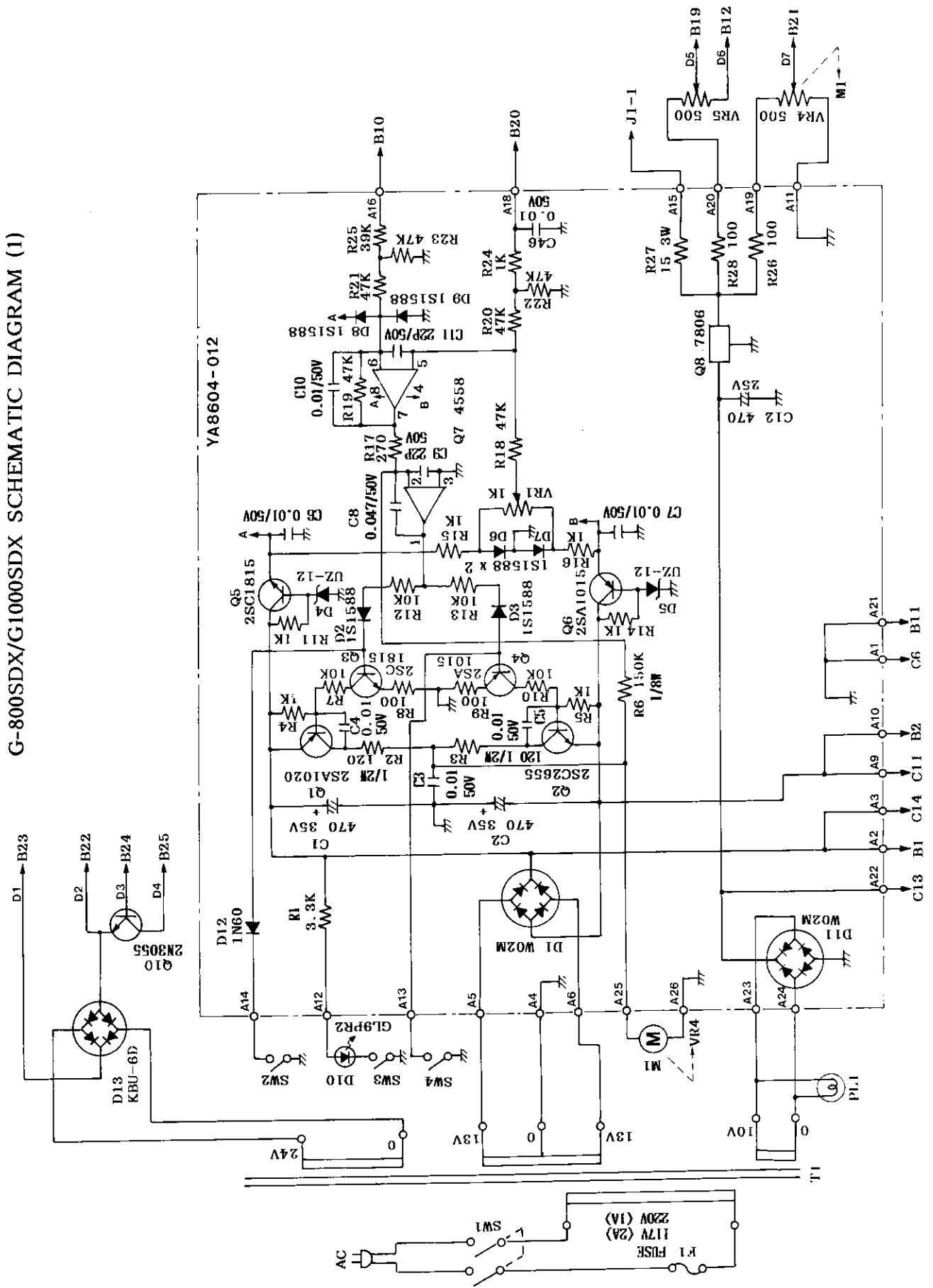

G-800SDX/G1000SDX SCHEMATIC DIAGRAM (2)

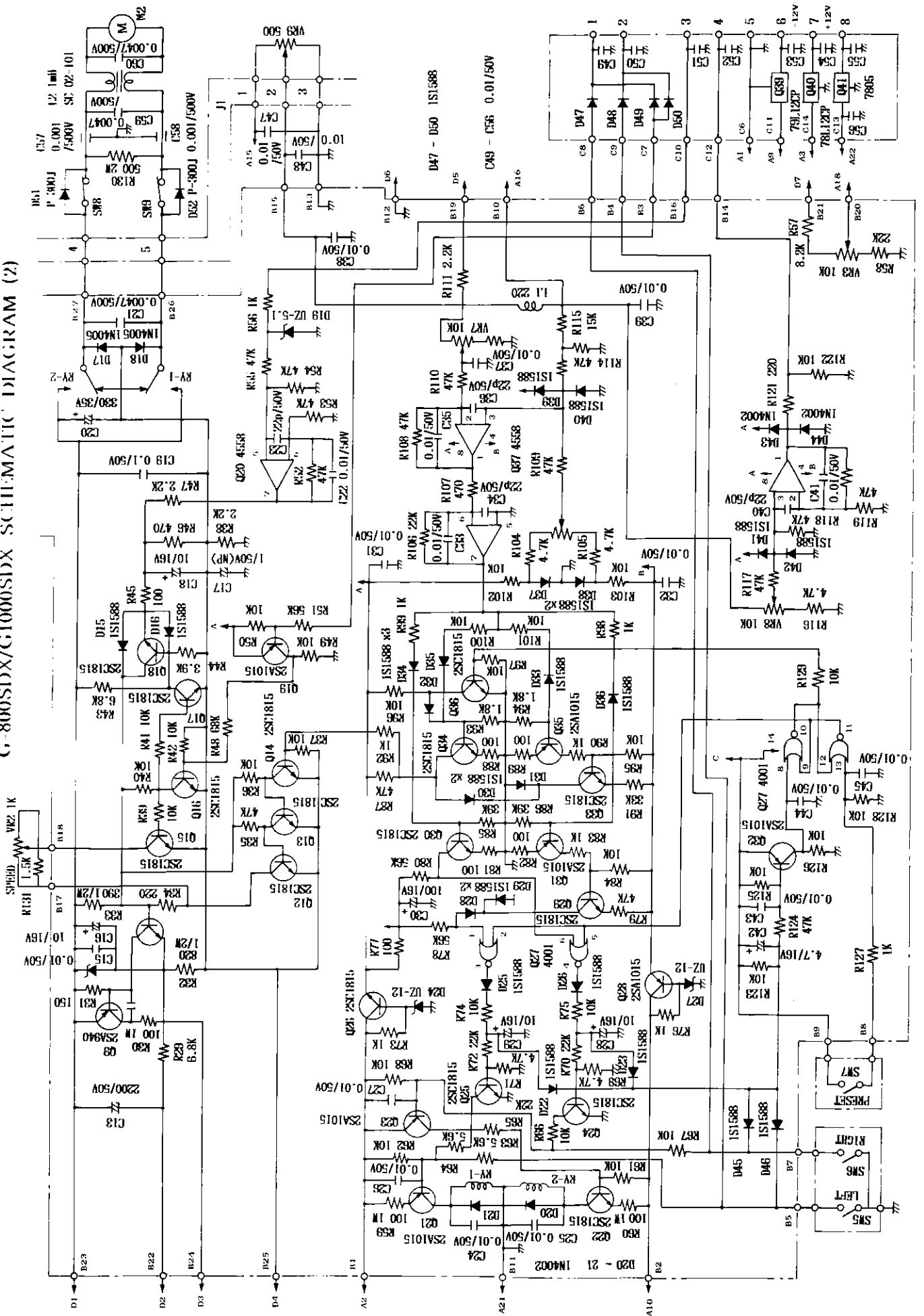

YAESU

Copyright 1994
Yaesu Musen Co., Ltd.
All rights reserved.
Printed in Japan.

No portion of this manual
may be reproduced
without the permission of
Yaesu Musen Co., Ltd.